

# PULSE GENERATION

## 9500/9600<sup>PLUS</sup> Series

multi-mode multi-channel multi-plexing multi-purpose



Exceptional pulse generators designed to fit your budget.

# Model 9500<sup>PLUS</sup> Series

## Standard Features

- 1 ns resolution - <400 ps jitter
- Independent control of width and delay up to 8 channels
- RS232, GPIB & USB communication interfaces
- 12 separate user storage configurations
- Advanced programming – Multiplexing, Channel Referencing, Burst, Wait, Duty Cycle, more...

## Advanced Features

- Ethernet computer interface
- 35 V high voltage outputs
- Extended timebase option
  - 10 MHz external phase lock reference
  - up to 20 MHz PRF



**The Model 9500<sup>Plus</sup> Series Digital Delay-Pulse Generator** with 2, 4 or 8 independent outputs is designed to provide cutting edge, yet cost-effective solutions to generate and synchronize multiple pulses for a variety of applications. The delay and pulsewidth for each channel are independent and digitally controlled which makes the instrument ideal for situations that require synchronizing a number of different events. Flexible operating modes allow complete control of pulse outputs, including continuous, duty cycle, burst and single shot with external trigger/gate. More advance features such as multiplexing allow the timing of all or several channels to be combined for complex pulse patterns. For automated test equipment, complete control of the instrument is provided through the standard RS232, USB and GPIB Interface - Ethernet is optional. LabVIEW<sup>®</sup> Drivers available.

## 9500<sup>Plus</sup> Series Synchronized Pulse Generation in Separate Modes

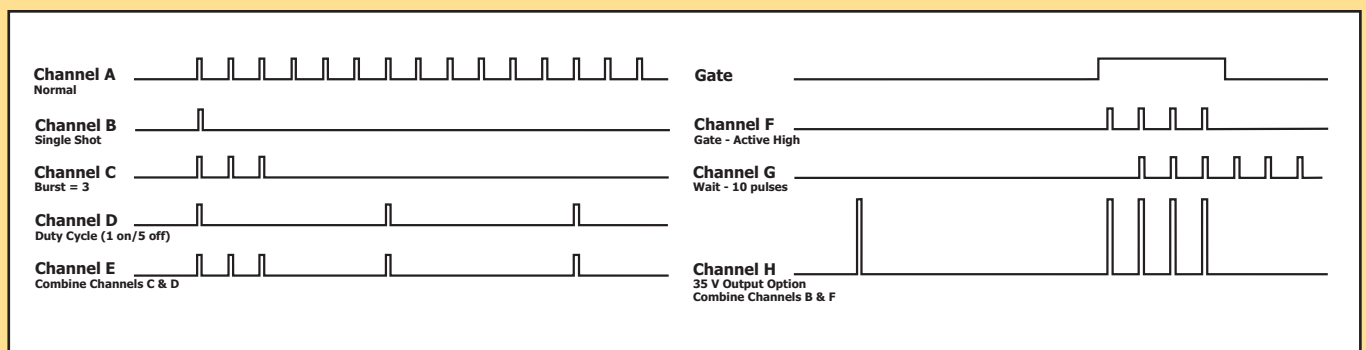

### Standard Features

- 10 ns resolution - <5 ns jitter
- Store up to 6 system configurations
- RS232 and GPIB interface available
- Flexible operating modes



**The Model 9600<sup>PLUS</sup> Series Digital Delay-Pulse Generator** with 2, 4 or 8 independent outputs is our most affordable digital delay/pulse generator - Ideal for applications that require moderate precision and multi-channel capability. The delay and pulsewidth for each channel are independent with 2-20 volt output range, allowing the user to drive a wide range of load circuitry. The instrument offers several operating modes, including continuous, burst, single shot and external trigger/gate, allowing complete control of the pulse outputs. With precise control of the delay periods and quick recall of up to 6 system configurations, the instrument is instantly ready for use. For automated test equipment, complete control of the instrument is provided through the standard RS232 interface - GPIB interface optional.

### Digital Delay using External Trigger for the 9500/9600<sup>PLUS</sup> Series

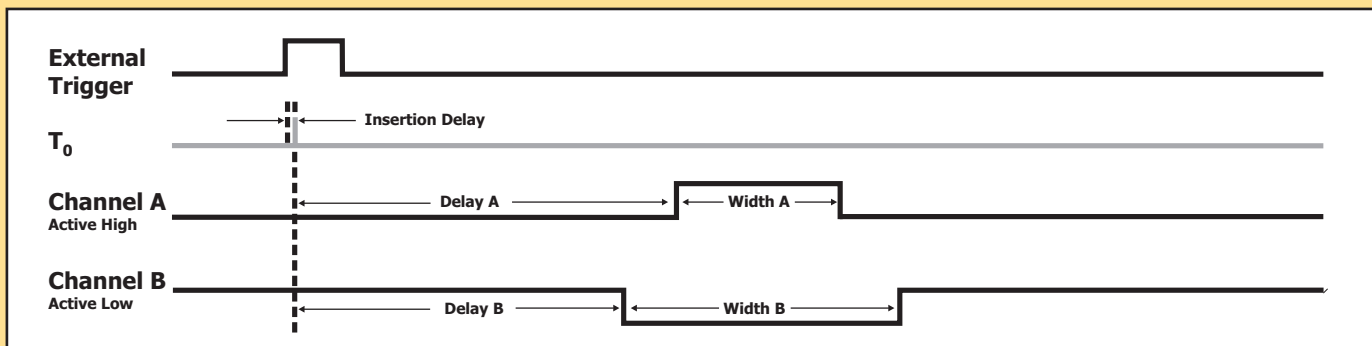

# SPECIFICATIONS

## 9500<sup>Plus</sup> Series

## 9600<sup>Plus</sup> Series

### MODELS

9512+ - 2 Channels, 2 independent outputs  
 9514+ - 4 Channels, 4 independent outputs  
 9518+ - 8 Channels, 8 independent outputs  
 All models have digital pulsewidth and delay control

9612+ - 2 Channels, 2 independent outputs  
 9614+ - 4 Channels, 4 independent outputs  
 9618+ - 8 Channels, 8 independent outputs  
 All models have digital pulsewidth and delay control

### PULSE GENERATION

modes	single shot, burst, continuous, duty cycle	single shot, burst, continuous, duty cycle
multiplexer	combine any channel	combine any channel
delay	0 - 1000 sec.	0 - 1000 sec.
pulsewidth	10 ns to 1000 sec.	10 ns to 1000 sec.
resolution	1 ns	10 ns
accuracy	1.5 ns + 0.0001 delay	10 ns + 0.0001 delay
time base	100 MHz, 25 PPM crystal oscillator	80 MHz, 50 PPM crystal oscillator
RMS jitter	<400 ps	<5 ns
burst mode	1 to 1,000,000	1 to 1,000,000

### EXTERNAL TRIGGER/GATE

rate	DC to 5 MHz	DC to 2 MHz
threshold	500 mV to 15 V	500 mV to 15 V
input range	0 - 30 V	0 - 30 V
trigger slope	rising or falling edge	rising or falling edge
RMS jitter	<5 ns	<25 ns
insertion delay	<150 ns	<250 ns

### INTERNAL RATE GENERATOR

modes	single shot, burst, continuous, duty cycle	single shot, burst, continuous, duty cycle
rate (T <sub>0</sub> period)	200 ns to 5000 sec. (0.0002 Hz to 5 MHz)	500 ns to 1000 sec. (0.001 Hz to 2 MHz)
resolution	10 ns	10 ns
accuracy	5 ns + 0.0001 x period	5 ns + 0.0001 x period
RMS jitter	<400 ps	<500 ps
burst mode	1 to 1,000,000 pulses	1 to 1,000,000 pulses

### OUTPUTS

outputs	TTL/CMOS, Adjustable 2 - 20 V, 35 V (optional)	Adjustable 2 - 20 V
impedance	50 Ohms	50 Ohms
slew rate	>0.5 V/ns	>0.2 V/ns
overshoot	<100 mV + 10% of pulse amplitude	<100 mV + 10% of pulse amplitude up to 4 independently adjustable outputs; 8 channel units 1 & 6, 2 & 7, ect. share the same output voltage.
amplitude (adjustable mode)	1 - 6 V into 50 Ohm load 2 - 12 V into high impedance load	1 - 10 V into 50 Ohm load 2 - 20 V into high impedance load

### CONFIGURATIONS

user set-up storage capacity	12	6
------------------------------	----	---

### COMPUTER INTERFACE

RS232	standard, 4800, 9600, 19200, 38400 57600 & 115200 Baud	standard, 4800, 9600, 19200 & 38400 Baud
GPIB Interface IEEE 488.2	standard	optional
USB Interface v 1.0	standard	n/a
Ethernet	optional (replaces standard USB)	n/a

### OPTIONS

E – Ethernet computer interface n/a  
 H – High voltage outputs (35 V)  
 T – Extended time base (10 MHz PLL / 20 MHz PRF)  
 I – Pulse incrementing  
 X – Separate gate and trigger inputs

### GENERAL

dimensions	10.5" x 8.25" x 5.5"	7.5" x 9" x 4"
weight	8 lbs.	6 lbs.
power	20 W, 100 - 240 VAC, 47 - 63 Hz <1 A	20 W, 100 - 240 VAC, 50 - 60 Hz
accessories	19" Rack Mount (single & double)	19" Rack Mount (single)

LabVIEW® is a registered trademark of National Instruments Corporation

